

PEST CONTROL

PUBLIC HEALTH DEPARTMENT

RASAL KAIMAH,
AREA = 29.75 Sq.M / 320.11 Sq.FT

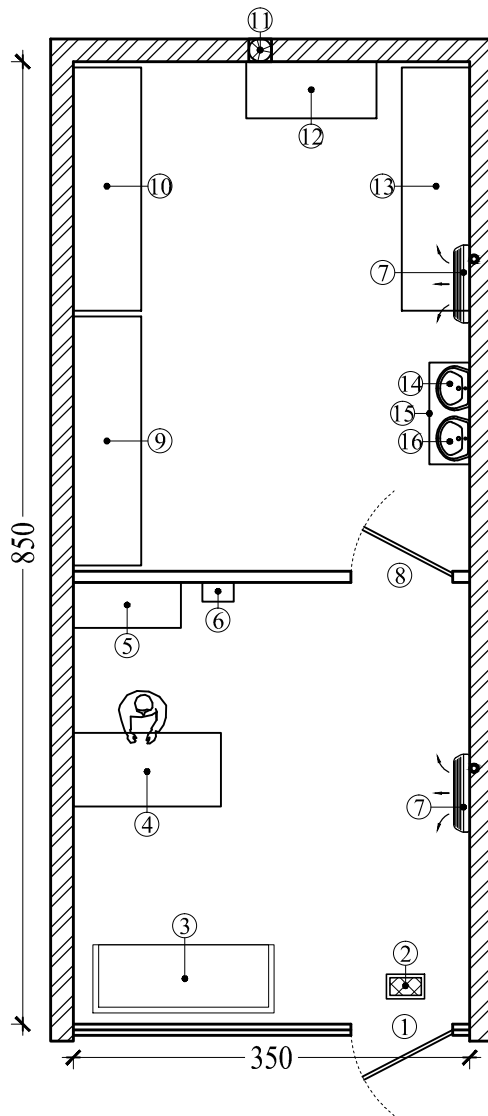

LEGENDS	
1	ENTRANCE
2	INSECT KILLER
3	WAITING AREA
4	RECEPTION
5	FILE CABINET
6	FIRST AID BOX
7	SPLIT A/C
8	DOOR TO STORE
9	STAND FOR CHEMICAL MATERIALS
10	STAND FOR PEST CONTROL PRODUCT
11	EXHAUST FAN
12	SHELVES FOR SPILL KIT
13	STAND FOR EQUIPMENTS
14	EQUIPMENT WASH
15	CHEMICAL STORE SHELF
16	STAFF HAND WASH

THE PROVIDED LAYOUT MODEL SERVES AS A -
 REFERENCE; ENSURE THE NEW LAYOUT -
 CONFORMS TO THE SPECIFIC PREMISE -
 DIMENSIONS AND REQUIREMENTS.

MODEL & STANDARD DESIGN OF PEST CONTROL